

BILL OF MATERIAL									
ABM	MARK	QTY	SHAPE	LENGTH	STEEL	REMARKS	COST	WEIGHT	
PG-LN	TOTAL							CODE	TOTAL
	S11813H1	1	HANDRAIL (19'-0")						13.2
	pp1922	1	PI 1-1/2" DIA SCH80	25'-3 11/16"	A53 GRB	APPROX			86.1
	BO-43	5	HR. BRACKET TO HANDRAIL	0'-6 5/16"	A36	BUY OUT			3.8
	p5155	1	FL 1/2" X 5 1/2"	0'-5 1/2"	A36				3.7
	pp1916	3	PI 1-1/2" DIA SCH80	3'-3 3/4"	A53 GRB				33.8
	pp1923	1	PI 1-1/2" DIA SCH80	4'-11 11/16"	A53 GRB	APPROX			16.9
	pp1926	3	PI 1-1/2" DIA SCH80	4'-5 1/16"	A53 GRB				45.1
	pp1927	1	PI 1-1/2" DIA SCH80	20'-11 15/16"	A53 GRB	APPROX			71.4
	r281	33	1/2" SQ. BANNISTER ROD	2'-8 3/8"	A36				132.5
	r282	1	1/2" SQ. BANNISTER ROD	2'-8 1/4"	A36				4.0
	r283	13	1/2" SQ. BANNISTER ROD	2'-6 7/8"	A36				49.8
	r284	1	R61 3/8"	0'-6"	A36				2.5
							TOTAL WEIGHT		450

TOTAL QTY	MARK	SHOP BOLTS	LENGTH	TOTAL QTY	MARK	FIELD BOLTS	LENGTH
2	S11813H1	1/2" DIA. HILLI. BOLT	4 5/16"				

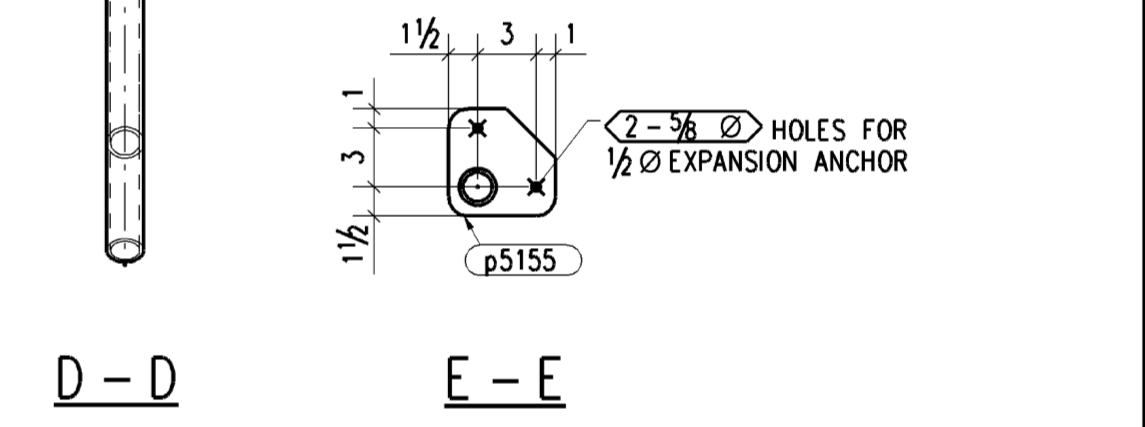
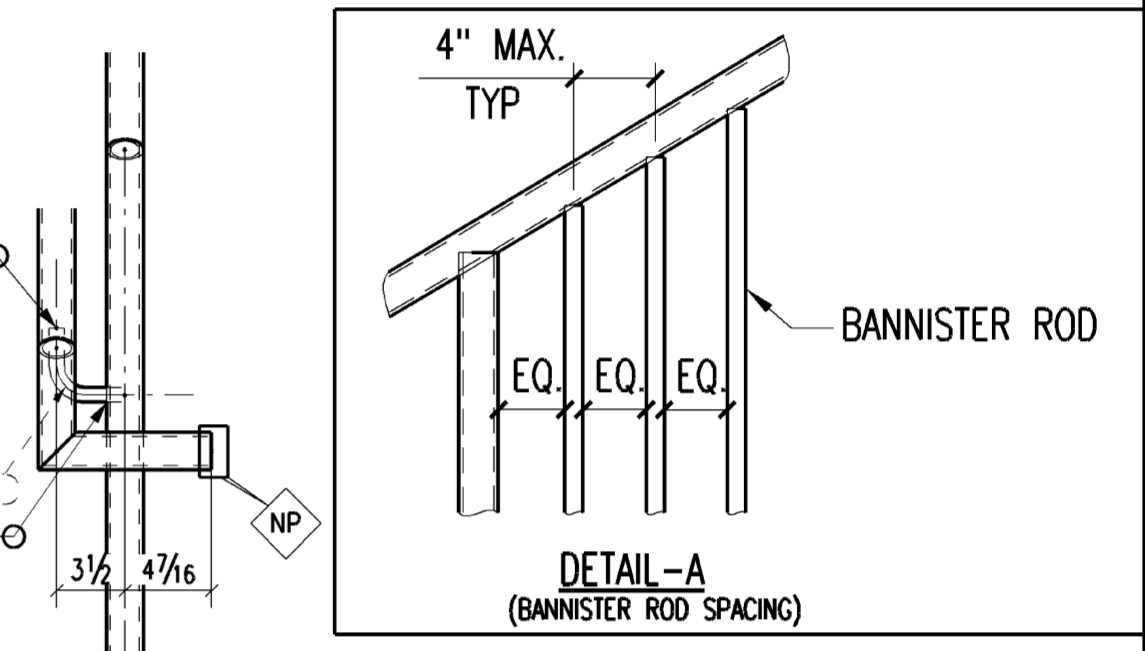

ALL WELDS SHALL BE SMOOTH FINISHED

ALL A325SC & A490SC SHOP & FIELD BOLTS SHALL BE A325SC-X AND A490SC-X RESPECTIVELY

REVISION AND DISTRIBUTION BOX						
REV	DATE	DESCRIPTION	BY	TO APPL	TO SHOP	TO FIELD

DRAWINGS ARE SUBMITTED FOR APPROVAL IN ACCORDANCE WITH AISC MANUAL NINTH EDITION - PAGE 5-228 PARAGRAPH 4.2 AND PAGE 5-250 SECTION 4.

SHOP NOTES:

- ALL RUNNING DIMENSIONS ARE TAKEN FROM THE LINE
- ALL GAS RE-ENTRANT CUTS WILL HAVE A RADIUS OF 1/2" UNLESS NOTED
- ALL SHOP BOLTS SHALL BE SNUG TIGHT UNLESS NOTED

MATERIAL: ASTM A36 UNLESS NOTED
WELD: E70XX - LH ELECTRODES
OPEN HOLES: 15° UNLESS NOTED
PAINT: PREP: COMMERCIAL BLAST CLEAN IN ACCORDANCE WITH SSPC-SP6
PRIME: AMERCOAT 88-S ORGANIC ZINC RICH PRIMER 2.3 MILS DFT
FINISH: AMERSHIELD FIS 15092 "DARK BLUE" 4.5 MIL DFT

BOLTS: 7/8" DIA A325SC-X, CLASS 8 (UNLESS NOTED)

DWG. DESCRIPTION: HANDRAIL DETAILS REF. PLAN

Aarbee Structures Private Limited
www.aarbeeeltdetail.com

CUSTOMER: _____ JOB NO. _____ EXTRA NO. _____
JOB TITLE: _____ DWG. NO. _____ REV. NO. _____
JOB LOCATION: _____
DWG. BY: _____ DATE: _____ CHK. BY: _____ DATE: _____